

# HELI

## CQDM12/15-810 Counterbalanced Reach Stacker

### Load Curve

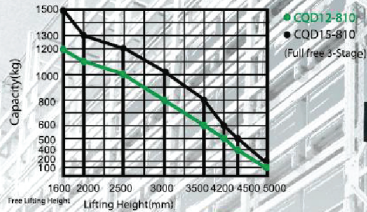
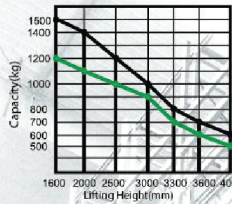

### Configuration and performance

- Fork tilt, double oil cylinder more smoothly.
- Electro-hydraulic integrated control, multi-function handle.
- Electronic power steering system, light and low noise.
- Two-way magnetic valve, three drop speed mode.
- AC Driving system, No carbon brush, maintenance free.
- Electromagnetic, regenerative braking system.
- Automatic lifting limit, proximity switch, long life.

### Safety

- Curve automatic deceleration devices, more safe.
- Vehicle decelerates automatically at higher position.
- Stepless speed control system, safe and quiet.
- Controller with Multiple automatic protection.
- Emergency reversing device/Emergency brake switch.
- High position automatic reduction device.

AC | EPS

Down mode at 3 speeds

Standard fork tilt device

Type	Lift height (mm)	Mast type	Outside width between forks (mm)	Inside width between forks (mm)
CQDM12/15-810	1400/2000/2500/3000/3300/3600/4000	Standard 2-STAGE	200-755	0-555
CQDM12/15-810	2500/3700/3900/4200/4500/5000	FULL FREE 3-STAGE		

Max lift height more than 3300, tilting device can not accept.

## CQDM12/15-810

Feature	CQDM12/15	CQDM12/15
Model	810	810
Configuration No.		
Type	Reach	Reach
Mast type	Standard 2-Stage	Full free 3-Stage
Load capacity	kg 1200/1500	1200/1500
Load center	mm 500	500
Wheel base	mm 1332	1332
Operating type	Stand On	Stand On
Wheels		
Wheels type	PU	PU
Wheel quantity/Driving wheel/ Balance wheel/Bearing wheel	1/0/2	1/0/2
Dimension		
Reach distance	mm 0-425	0-425
Standard lift height	mm 1400/2000/2500/3000/3300/3600/4000	2500/3700/3900/4200/4500/5000
Max. extend height	mm 2280/2880/3380/3880/4180/4480/4880	3405/4605/4805/5105/5405/5905
Mast lowered height	mm 1490/1790/2040/2290/2440/2590/2790	1432/1870/1940/2040/2140/2359
Lowered fork height	mm 55	55
Fork size (length/width/thickness)	mm 1070/100/40	1070/100/40
Overall length	mm 2440/2896	
Overall width	mm 1083	1083
Outside width between forks	mm 200-755	200-755
Tilt of fork (F/B)	mm 3/5	3/5
Min. Turning radius	mm 1596/2040	1596/2040
Min. Aisle width for pallets 800×1200	mm 2620/3050	2620/3050
Min. Aisle width for pallets 1000×1200	mm 2645/3075	2645/3075
Min. ground clearance	mm 60	60
Performance		
Travel speed, laden/unladen	km/h 5/5.5	5/5.5
Lift speed, laden/unladen	mm/s 130/180	130/180
Lowering speed, laden/unladen	mm/s 100/180	100/180
Gradeability, laden/unladen	% 3/5	3/5
Electrical configuration		
Drive motor/Lift motor/Steering motor	KW AC1.5/DC3.0/DC0.15	AC1.5/DC3.0/DC0.15
Battery voltage	V 24	24
Battery capacity	Ah 280	280
Brake	Electromagnetic/Regenerative	Electromagnetic/Regenerative
Controller	ZAPI	ZAPI
Weight		
Battery weight	kg 235	235
Service weight with battery	kg 2185	2205

\* Details of specifications and equipment are based on information available at time of printing and may change without notice.

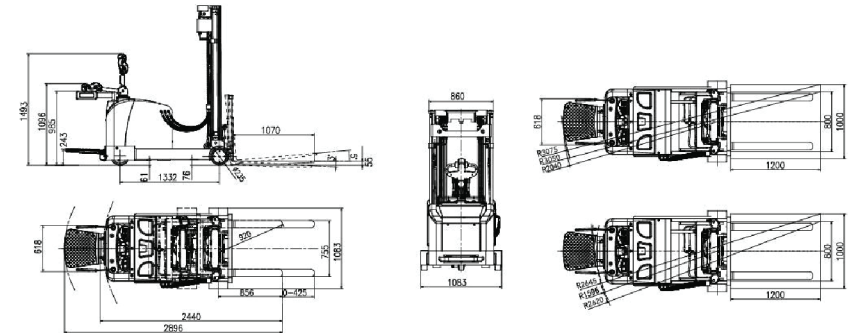

PT. BADAK PRIMA LESTARI

Kawasan Industri Millenium, Jl. Millenium 15 Blok I-2 No. 3A, Desa Peusar,  
Kecamatan Panongan, Kabupaten Tangerang, Banten 15710 INDONESIA

Tel: +62 59986616 / 30, Fax.: +62 59986847

www.badakprima.co.id